

Panasonic®

Digital Imaging Systems Quick Guide (For Facsimile and Internet Fax/Email)

Model No. **DP-1820P/1820E**

Table of Contents

Getting To Know Your Machine

Connecting the Cables	2
Safety Information.....	3
Control Panel.....	4
Basic Operation Chart	8
Mode Setting.....	12

Problem Solving

Information Code.....	14
-----------------------	----

Symbols/Icons



Place original(s) on the
ADF/i-ADF



Press any Hard Key on the
Control Panel

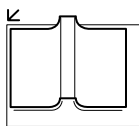

Place original on the Platen
(Book)



Go to next step

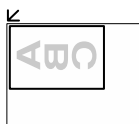

Place original on the Platen
(Sheet)



Go to next step (below)

WORKIO™

Before operating this equipment, please read these instructions completely and keep these operating instructions for future reference.

NOTE: The reference page numbers shown in this Quick Guide, depict the page number(s) in the Operating Instructions included on the CD (For Facsimile and Internet Fax/Email).

English

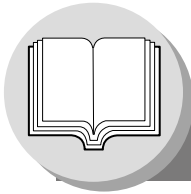

Getting To Know Your Machine

Connecting the Cables

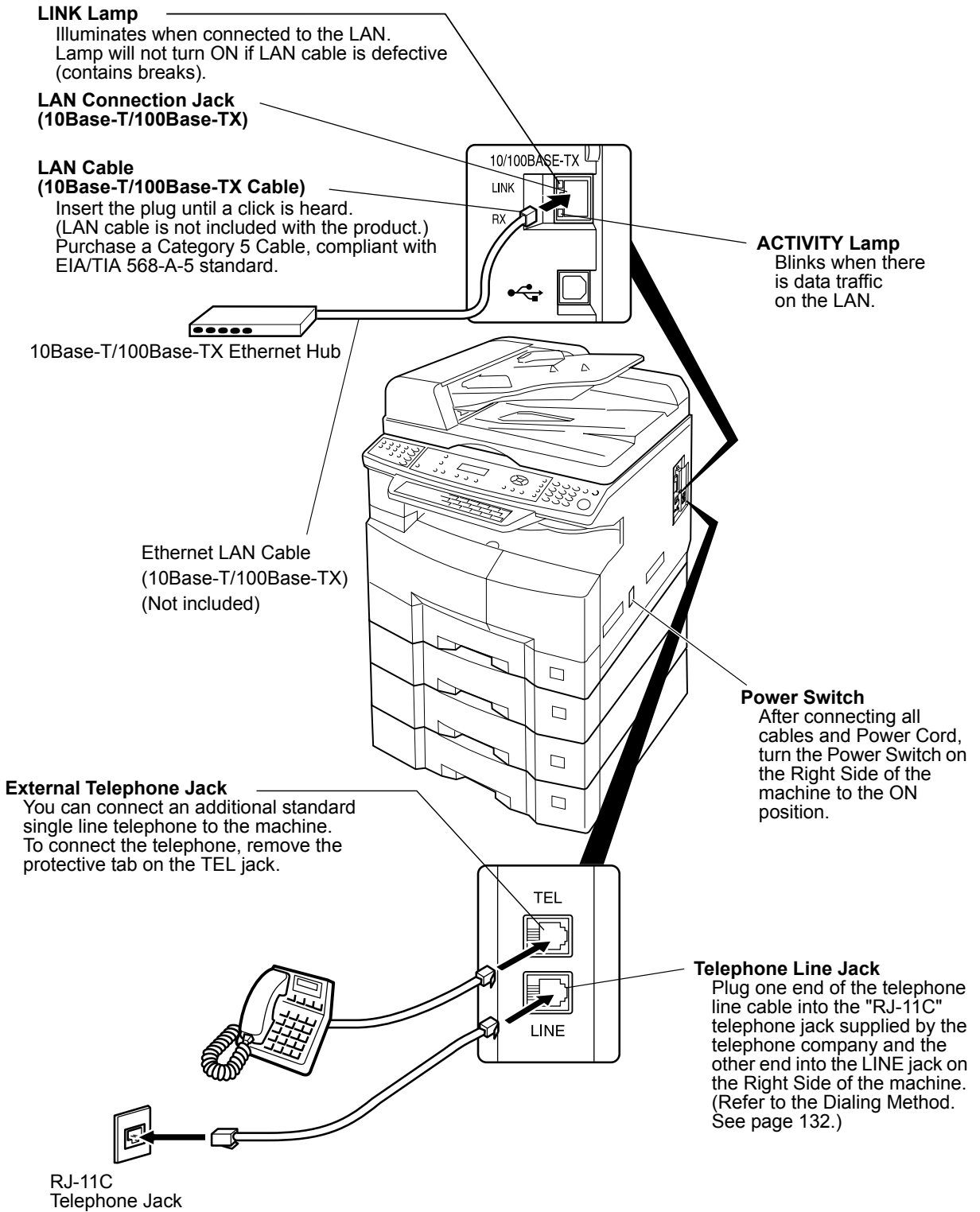

Safety Information

⚠ CAUTION Denotes hazards that could result in minor injury or damage to the machine.

- TO REDUCE THE RISK OF SHOCK OR FIRE, USE ONLY NO. 26 AWG OR LARGER TELEPHONE LINE CABLE.
- DISCONNECT ALL POWER TO THE MACHINE BEFORE COVER(S) ARE REMOVED. REPLACE THE COVER(S) BEFORE THE UNIT IS RE-ENERGIZED.

⚠ IMPORTANT SAFETY INSTRUCTIONS

When using your telephone equipment, basic safety precautions should always be followed to reduce the risk of fire, electric shock and injury to persons, including the following:

- DO NOT USE THIS PRODUCT NEAR WATER, FOR EXAMPLE, NEAR A BATH TUB, WASH BOWL, KITCHEN SINK OR LAUNDRY TUB, IN A WET BASEMENT OR NEAR A SWIMMING POOL.
- AVOID USING A TELEPHONE (OTHER THAN A CORDLESS TYPE) DURING AN ELECTRICAL STORM. THERE MAY BE A REMOTE RISK OF ELECTRIC SHOCK FROM LIGHTNING.
- DO NOT USE THE TELEPHONE TO REPORT A GAS LEAK IN THE VICINITY OF THE LEAK.

SAVE THESE INSTRUCTIONS.

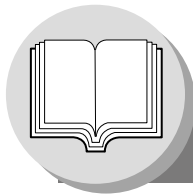





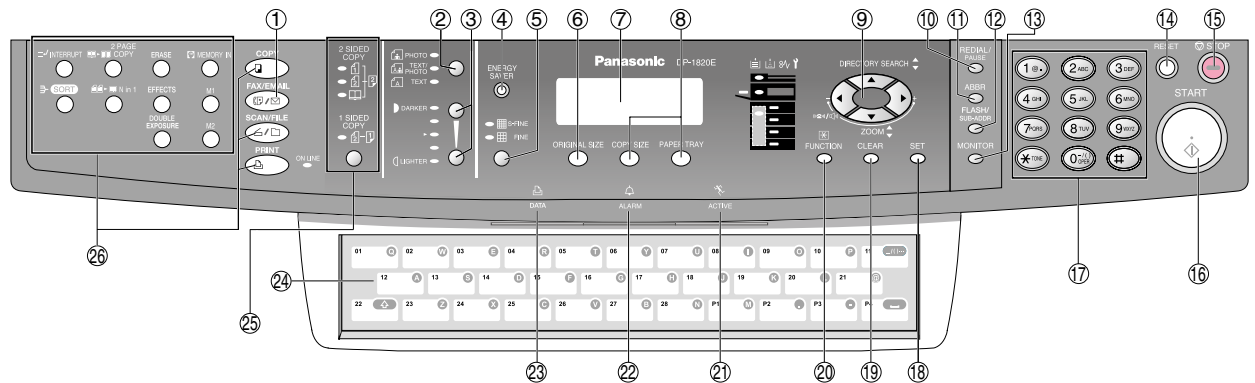



Getting To Know Your Machine

Control Panel

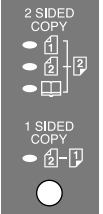

No.	Icon	Contents	No.	Icon	Contents
1		FAX/EMAIL Key Used to select the FAX/EMAIL mode. To change the input mode between Email Address and Telephone Number.	2		ORIGINAL Key Used to select type of Original. (See page 11)
3		CONTRAST (Lighter/Darker) Key Used to adjust the Manual Exposure.	4		ENERGY SAVER Key Used to switch the machine into Energy Saver Mode.
5		RESOLUTION Key Used to set Standard, Fine, Super-Fine (400 or 600 dpi). (See page 11)	6		ORIGINAL SIZE Key Used to select the Original Size manually. (See page 11)
7		LCD Display Indicates Number of Copies / Original(s) / Machine / User Error Code.			
9		Cursor Keys <ul style="list-style-type: none"> Adjust the Monitor and Ringer Volume. Move the cursor while entering numbers and characters. Search the Station Name for Directory Search Dialing. Confirm the entered station for multi-station communication. Select functions. Confirm the current communication modes (e.g. Page Number, ID, Dialed Telephone Number or Email Address, File Number) when the unit is ON LINE. 			
10		REDIAL/PAUSE Key Used to enter a pause when recording or dialing a Telephone Number, or to redial the last dialed number.	11		ABBR Key Used to start Abbreviated Dialing. (See pages 10, 22 and 58)
12		FLASH/SUB-ADDR Key Used to separate the Sub-Address from the Telephone Number when dialing, or to access some features of your PBX.	13		MONITOR Key Used to start On-Hook Dialing or to input a space between numerical entries (such as, while entering telephone numbers). (See pages 26 and 132)
14		RESET Key Resets all features to the initial power-on state.	15		STOP Key Press this button when you want to Stop a telecommunication, registration operation or audible tone.

No.	Icon	Contents	No.	Icon	Contents
16		START Key Press this button to Start transmitting or receiving a fax.	17		Keypad Used for manual number dialing, recording phone numbers and numerical entries. Used to input Characters when a Keyboard option is not installed.
18		SET Key Used to Set operations.	19		CLEAR Key Use this button when correcting entered numbers or characters.
20		FUNCTION Key Used to start or select functions and subfunctions. These functions are explained in detail on page 14.	21		ACTIVE LED (green) Flashes: When machine is active. Lights: When the received fax message is in memory.
22		ALARM LED (red) Lights/Flashes when trouble occurs. Lights: Machine detected a trouble status. <ul style="list-style-type: none"> No paper in the selected tray or toner has run out. Machine detected trouble, such as paper misfed or jammed. Flashes: Machine detected an alarm status. <ul style="list-style-type: none"> No paper in the Tray. (Tray not selected) Toner is getting low, etc. 	23		PRINT DATA LED (green) Flashes: When receiving printing data. Lights: While printing.
24		Keyboard (Option) <ul style="list-style-type: none"> Used to input the Characters. (To switch between Upper/Lower characters, press Shift key (⇧)) Used for One-Touch Keys, Program Keys. Used to enter a symbol for the LOGO, Character ID, Station Name and for the Email Address. Use ▼ or ▲ to select the desired symbol(s). 			
25		2-Sided Key Used for 2-Sided transmission. (Available when the i-ADF (DA-AR202) option is installed.)			
8		Used for Copier, Network Scanner and Printer Functions.			
26					

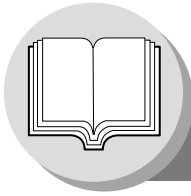

Getting To Know Your Machine

Control Panel

How To Enter Characters

To enter characters or symbols follow the steps below.

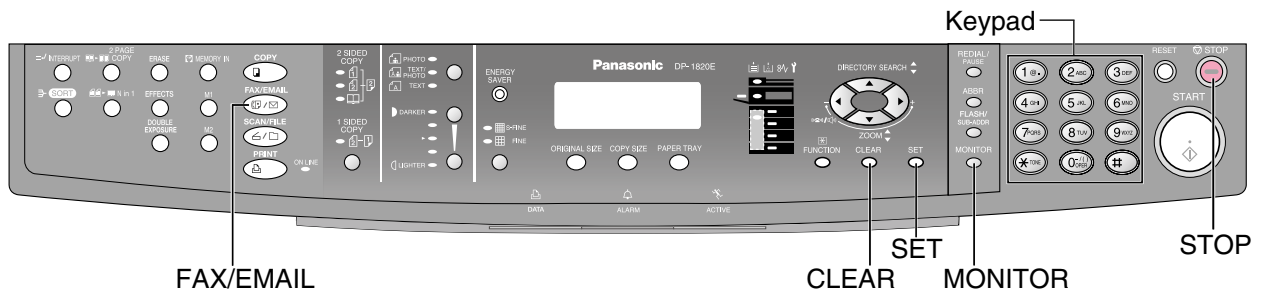

- Use ① to ⑨ on the keypad to enter characters and symbols. The keypad assignment for the characters and symbols is shown below. The "1 @ -" key is also used to enter a period "." during Email or IP Address input.

Ex: To enter "Panasonic"

Character	Keypad	Key Strokes
P	⑦ PORS	6
a	② ABC	2
n	⑥ MNO	3
a	② ABC	2
s	⑦ PORS	5
o	⑥ MNO	4
n	⑥ MNO	3
i	④ GHI	4
c	② ABC	4

Ex: LOGO

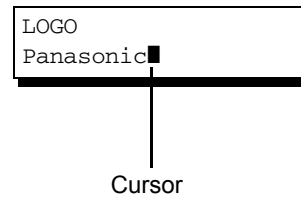

NOTE

- When the Keyboard Option (DA-KB180) is installed, the keypad reverts to Numerical entries only.

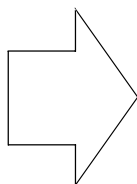

Character Table and Required Number of Key Strokes														
	1	2	3	4	5	6	7	8	9	10	11	12	13	14
①	1 @ . Ä ä Ã ä Ö ö Ü ü È è É é Æ æ Ñ													
①	1 @ .													
② ^{asc}	2	a	b	c	A	B	C							
③ ^{sp}	3	d	e	f	D	E	F							
④ ^{sh}	4	g	h	i	G	H	I							
⑤ ^{sl}	5	j	k	l	J	K	L							
⑥ ^{mp}	6	m	n	o	M	N	O							
⑦ ^{ps}	7	p	q	r	s	P	Q	R	S					
⑧ ^{tr}	8	t	u	v	T	U	V							
⑨ ^{wp}	9	w	x	y	z	W	X	Y	Z					
⑩ ^{nl}	0 - / () _ ' : % & + =													
⑩ ^{nl}	0 - / () _ ' : & + = ! " \$ < > % ? [] ^ ` { }													

- Select and continue pressing the appropriate key on the keypad until the desired Character / Symbol is displayed, then select another key on the keypad to enter the next Characters / Symbols. If the next Character / Symbol that you wish to enter falls on the same key, press , to set the first Character / Symbol before continuing. Press to complete the registration.

Ex: To input an "o" and "n", the ⑥ key is used for both Characters.

Enter as follows: ⑥ x 4  ⑥ x 3

- To delete a Character / Symbol, press .
- To enter a space, press .
- Upper case characters are typically used to enter Station Name, etc. Lower case characters are typically used to enter E-mail Addresses.

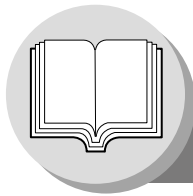

Getting To Know Your Machine

Basic Operation Chart

Basic Operation

1

From ADF/i-ADF (Option)

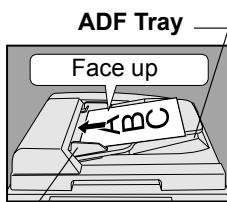

or From Platen

Original Guides
Adjust to the original's width.

Original Guides

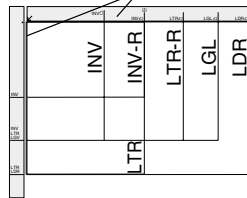

INV: Invoice, LTR: Letter
LGL: Legal, LDR: Ledger

- Place originals face down on the Platen or face up on the ADF/i-ADF.
- For originals smaller than Invoice size, position the original within the Invoice area and select Invoice.
- Select original size when placing the document on the Platen.

4a One-Touch/ABBR Dialing (see Note 3) (One-Touch is available when a Keyboard option is installed.)

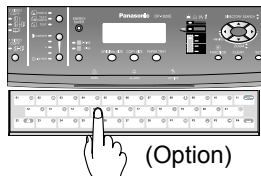

or



ABBR + ABBR No.
(3-digit)

When the Telephone Number(s) or Email Address(es) are registered in the One-Touch/Abbreviated Dialing.

or

4b Manual Number Dialing (Up to 50 Stations)



Change to Email Address or Telephone No. input mode.

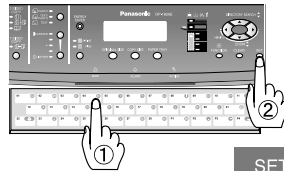

or

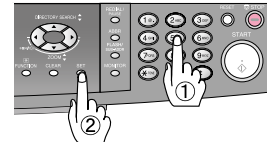

Email Address or Telephone Number + SET

or

(When a Keyboard option is installed)

4c Directory Search Dialing (see Note 3)

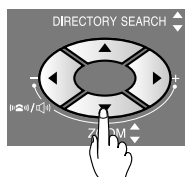

▼ or ▲

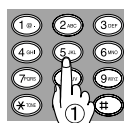

or

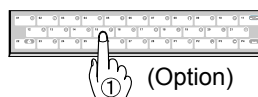

(Option)

Enter the first letter(s) of the name you wish to search.
Ex: "SA"

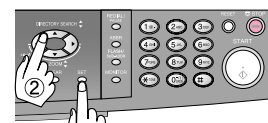

SET

ENTER LETTER(S)

SA

[100] SALES 3

[005] SALES 2

[001] SALES

☎ 5551234

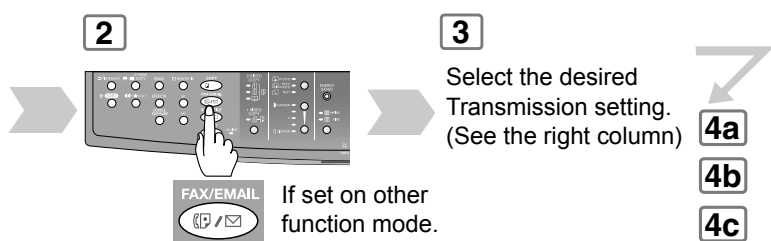

2

3

Select the desired Transmission setting. (See the right column)

4a
4b
4c

FAX/EMAIL If set on other function mode.

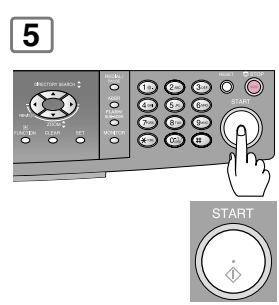

The document(s) is stored into memory with a file number. Then starts sending the document(s).

6

When an original is scanned from the Platen Glass, the message "ANOTHER ORIGINAL?" is shown.

1@. Place another original, then press **START**.

2ABC Machine starts sending.

Sending Non-Standard Size Documents

When transmitting non-standard size document(s), the machine will not send the portion of the document that exceeds the standard size ("P" portion).

The portion labelled "P" that exceeds the standard documents size is not sent.

Transmission Settings

S-FINE for finer detailed originals (400 or 600 dpi, see page 146)

FINE for detailed originals

STANDARD for standard originals (both LED lights go out)

PHOTO for photo or illustration originals

TEXT/PHOTO for text and photo originals

TEXT for text only originals

LETTER : Letter

LETTER : Letter-R

INVOICE : Invoice

INVOICE : Invoice-R

LEDGER : Ledger

LGL : Legal

* ORIGINAL SIZE key is used for Platen Glass.

* Legal size with ADF only.

NOTE

1. If your machine sounds an alarm (pi-pi-pi) in Step 4 above, this indicates that the Dialer is Full (more than 50 full Email Addresses are entered or 50 transmission reservations including G3 communication have been already reserved).
2. To utilize the Email functions, your machine needs to be set up properly on your network. Please contact your network administrator for actual network setup.
3. Auto Dialer (One-Touch/ABBR.) is only available when stations are registered. (See page 136)
4. When transmitting in Photo or S-Fine mode, there is a possibility that printing quality may deteriorate at the remote station due to its reception capability. If this occurs, re-send with Direct Transmission or use "Fine" Resolution.
5. You can send the same document(s) to multiple stations by repeating Steps 4a, 4b or 4c, and then pressing **START**.
6. To stop the transmission, see page 12.

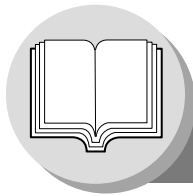

Getting To Know Your Machine

Basic Operation Chart

■ To Stop the Transmission

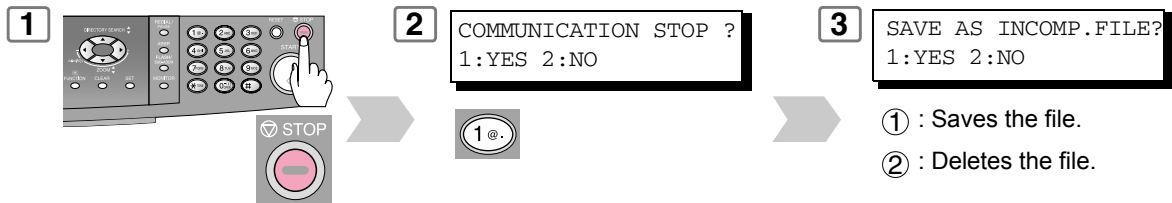

- ① : Saves the file.
- ② : Deletes the file.

- If Fax Parameter No. 31 (**INC. FILE SAVE**) is "Valid". (See page 145)
- To retry an Incomplete File, see page 108.

■ Rotated Transmission

Letter or A4 size Original(s) are placed in a Portrait (←□) direction, the document(s) will be rotated by 90° and then transmitted in a Landscape (→□) direction. The document(s) will be printed the same size as the transmitted originals at the Receiving Station.

Fax Parameter No. 78 (ROTATION XMT) set to:

- Invalid

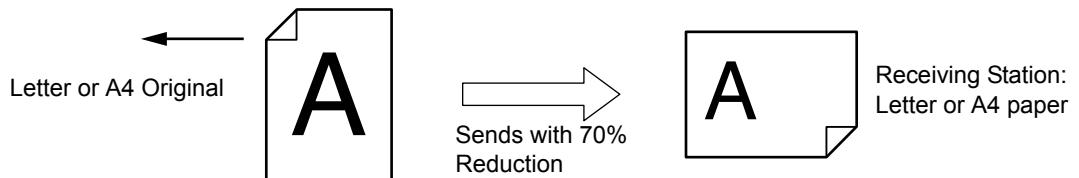

■ 2-Sided Transmission (Scan)

This machine has duplex SCAN capabilities. (It is available when the i-ADF (DA-AR202) option is installed.)

Scanning 2-Sided Original(s) using the Basic Menu:

- 2-Sided Original = ON (1 SIDED COPY lights)

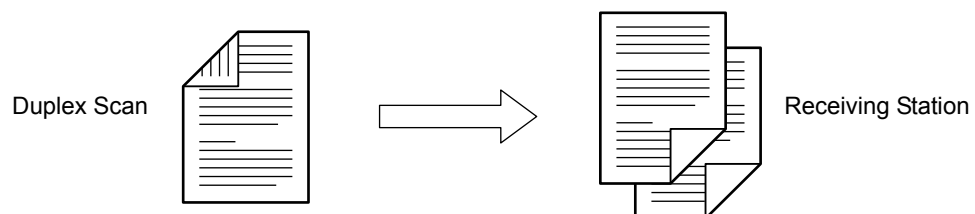

NOTE

1. To select the Comm. Journal printout condition, change the setting of Fax Parameter No. 12. (See page 144)
2. If the Email transmission cannot be completed for any reason, the Email may be returned undelivered; otherwise no reply will be printed.

4 PRINT COMM. JOURNAL?
1: YES 2: NO



Print Communication Journal
(COMM. JOURNAL).

5

Stop the transmission.

• **Valid** (Default Position)

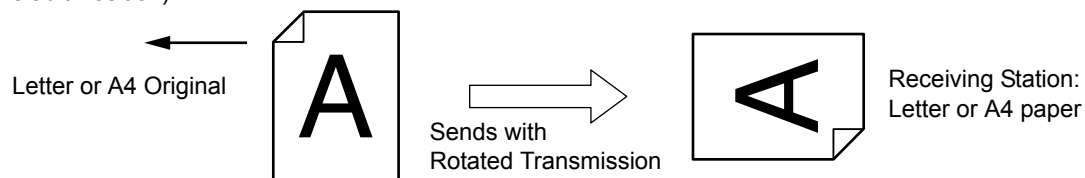

NOTE

3. Rotation XMT requires the use of Memory Transmission.
4. Verification Stamp is disabled during 2-Sided Scanning.

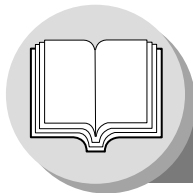

Getting To Know Your Machine

Mode Setting

■ Changing the Modes

Any function can be started by first pressing **FUNCTION** and then entering the function number, or by pressing or scroll key repeatedly until the desired function appears on the display.

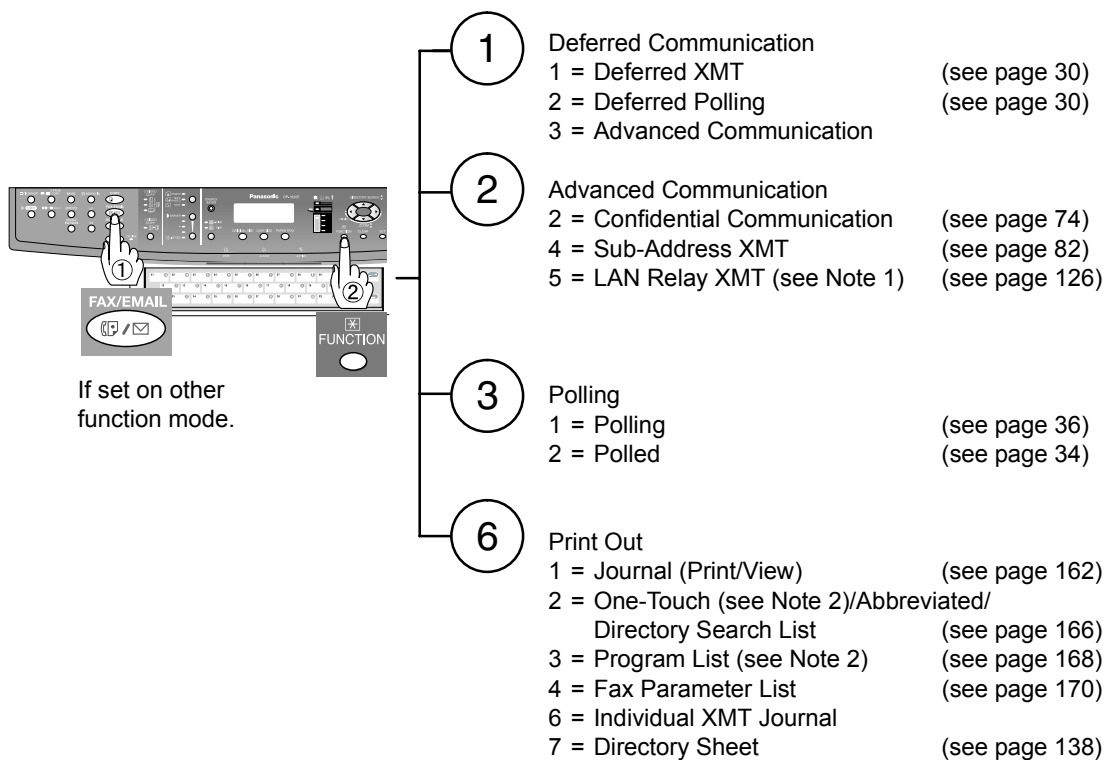

NOTE

1. If Fax Parameter No. 140 is not preset to "Valid" position, which enables you to use its function, the display will not show the function. (See page 146)
2. These functions are available when the optional Keyboard (DA-KB180) is installed.

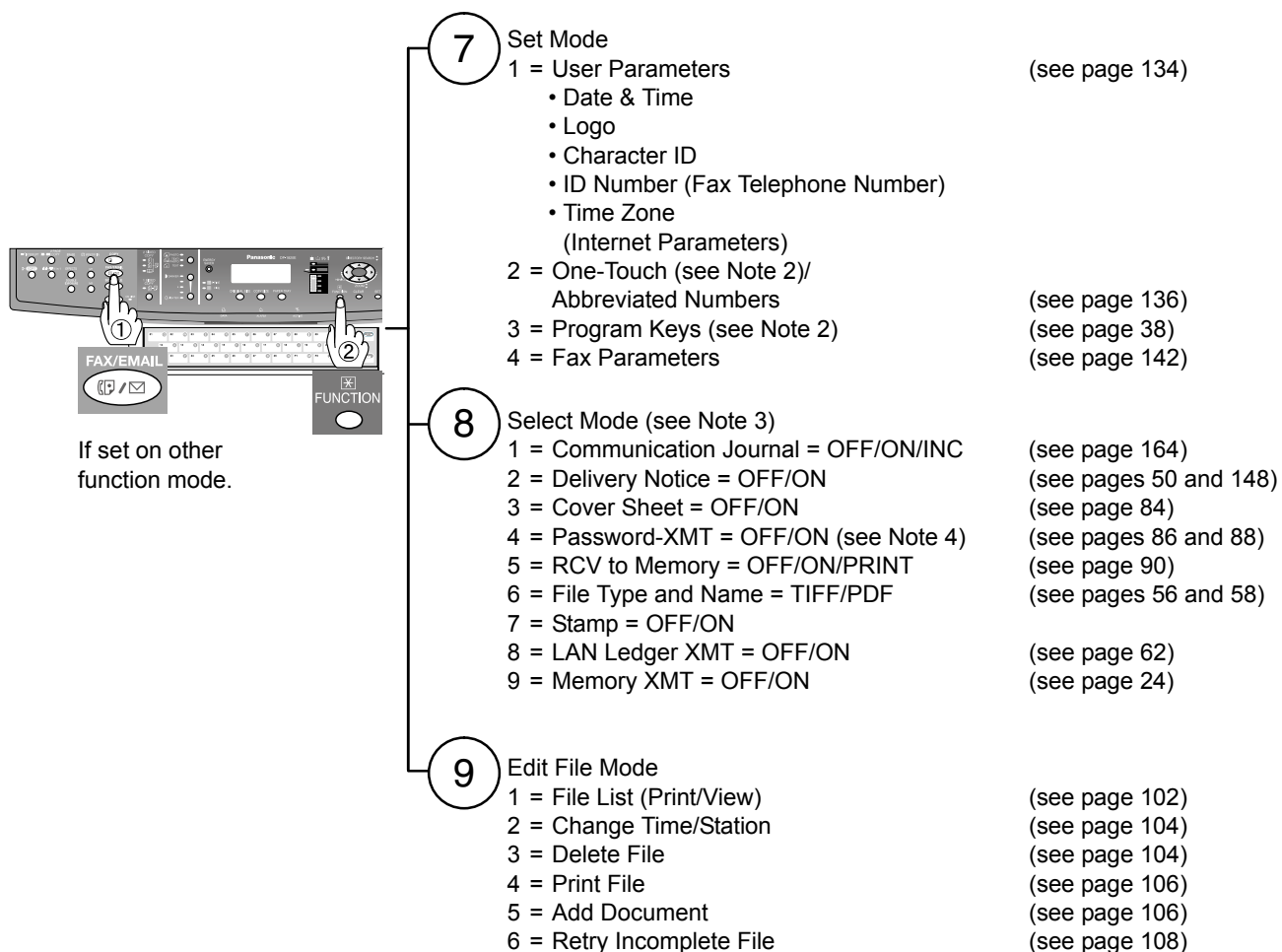
**NOTE**

3. The Select Mode (**FUNCTION** **8**) settings can be temporarily changed for the current communication. Upon its completion, however, these parameters are returned to their preset default values (Home position). You can change the Home position of these settings in the Fax Parameters mode. (See page 142)
4. If Fax Parameter No. 43 is not preset to the "ON" position, which enables you to use its function, the display will not reveal this function. (See page 145)

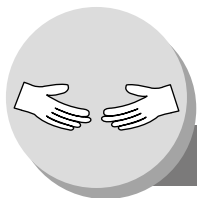

Problem Solving

Information Code

When an anomaly occurs, the display may show one of the Information Codes listed below. These will help you to identify and correct the problem.

Info. Code	Meaning	Possible Action	Page
030	Document is misfeeding.	1. Reload the document properly. 2. Remove the document jam. 3. Adjust ADF.	10
031	Document is too long or jammed. Document length exceeds 78.8 inches (2 meters) in "Normal" and "Fine" mode only. The length limitation for "Super Fine" (400 and 600 dpi) mode, is subject to the available Memory size. 400 dpi 600 dpi (Max. Length) (Max. Length) A4/Letter Width: 55 in (1400 mm); 24 in (600 mm) A3/Ledger Width: 39 in (990 mm); 17 in (430 mm)	1. Reload the document properly. 2. Remove the document jam.	10
061	ADF Cover (Document Return Guide) is open.	Close the ADF Cover.	--
400	During initial handshake, receiving station did not respond or communication error occurred.	1. Check with the other party. 2. Reload the document and send again.	--
401	Remote station required a Receiving Password to receive the document. Remote station does not have Confidential Mailbox.	Check the remote station.	--
402	During initial handshake, communication error occurred.	Reload the document and send again.	--
403	No polling capability at the remote side.	Ask remote side to set "POLLED=ON".	--
404/405	During initial handshake, communication error occurred.	Reload the document and send again.	--
406	Transmission Password does not match. Receiving Password does not match. Received from an unauthorized station in Selective Reception mode.	Check the password or the telephone number in One-Touch or Abbreviated station.	86 94
407	No confirmation from the receiving station for the previous page sent.	Wait a few minutes and send again.	--
408/409	Remote side confirmation of previous page is illegible.	Wait a few minutes and send again.	--
410	Communication aborted by the transmitting side.	Check with the other party.	--
411	Polling password does not match.	Check the polling password.	36
412	No data from the transmitting side.	Check with the other party.	--
414	Polling password does not match.	Check the polling password.	36
415	Polling transmission error.	Check the polling password.	36
416/417/ 418/419	Received data has too many errors.	Check with the other party.	--
420/421	Machine goes to receiving mode, but receives no command from the transmitting side.	1. Remote side misdial. 2. Check with the other party.	--
422/427	Interface is incompatible.	Check with the other party.	--

Info. Code	Meaning	Possible Action	Page
430/434	Communication error occurred while receiving.	Check with the other party.	--
436/490	Received data has too many errors.	Check with the other party.	--
456	<ul style="list-style-type: none"> • Unit received a confidential document or was requested to be polled of a confidential document under any of following conditions. <ol style="list-style-type: none"> 1. Not enough space in memory to receive the confidential document. 2. Confidential Mailbox is full. 3. While printing received document. • Unit was requested to relay a document. 	<ol style="list-style-type: none"> 1. Print a File List and check the contents. 2. Wait until unit finishes printing. 	102
492/493/ 494	Communication error occurred while receiving.	Check with the other party.	--
495	Telephone line disconnected.	Check with the other party.	--
501/502/ 503/504	Communication error occurred using the internal V.34 Modem.	Check with the other party.	--
540/541/ 542/ 543/544	Communication error occurred while transmitting.	<ol style="list-style-type: none"> 1. Reload the document and send again. 2. Check with the other party. 	--
550	Telephone line disconnected.	Check with the other party.	--
552/553/ 554/555	Communication error occurred while receiving.	Check with the other party.	--
580	Sub-Address Transmission to a unit that has no Sub-Address function.	Check the remote station.	82
581	Sub-Address Password Transmission to a unit that has no Password Sub-Address function.	Check the remote station.	82
623	No document loaded on the ADF.	Reload the document and send again.	--
630	Redial was not successful due to a busy line.	Reload the document and send again.	--
631	During dialing, STOP was pressed.	Reload the document and send again.	--
634	Redial was not successful due to no response from the called station or wrong number dialed. Note: If busy tone was not detected, the machine will only redial once.	Check the telephone number and send again.	--
638	Power failure occurred during the communication.	Check the power cord and plug.	--
711	Incorrect LDAP settings.	Check the LDAP Server Name, LDAP Login Name, LDAP password, LDAP Search Base.	54 55
712	Incorrect email address.	Check the email address and send again. Check the IP Address of the SMTP Server with the Network Administrator.	--
714	Cannot Log on to the LAN.	Check the 10Base-T/100Base-TX cable connection. An unexpected LAN problem occurred. Contact the Network Administrator.	--

Continued on the next page...



Problem Solving

Information Code

Info. Code	Meaning	Possible Action	Page
715	TCP/IP connection timed out.	Check the Internet Fax Parameter settings. Verify the IP Address, Default Gateway IP Address, SMTP Server IP Address.	--
716	Cannot logon to the designated SMTP Server.	Check the SMTP Server IP Address setting. Contact the Network Administrator.	--
717	Incomplete SMTP Protocol transmission. SMTP Server's hard disk may be full.	SMTP Server is defective. Contact the Network Administrator.	--
718	Page Memory Overflow occurred while receiving printing data. The paper size selected within your application to print is larger than the paper size loaded in the cassette(s).	Check the document size and resolution. Ask originator to resend in a supported size and resolution.	--
719	Received data via LAN is in a format that is not supported.	Ask the originator to resend with a supported file attachment format: * In a TIFF-F format. * Image data conforming to recording paper size.	--
720	Cannot connect to the POP Server. (Incorrect POP Server IP Address) POP Server is down.	Check the POP Server IP Address. Contact the Network Administrator.	--
721	Cannot connect to the POP Server. (User Name or Password error)	Check the POP User Name and Password or the APOP settings. Contact the Network Administrator.	--
722	Failed to obtain IP address from the DHCP server.	Check the 10Base-T/100Base-TX cable connection. Confirm that the Internet Parameter and the DHCP server are correctly configured before turning On or turning Off the power. Contact the Network Administrator.	16
725	DNS Server connection timed out. DNS Server is down.	Check the DNS Server IP Address. Contact the Network Administrator.	--
726	Received an error response from the DNS Server.	Check the POP Server Name. Check the SMTP Server Name.	--
728	The document was sent to the Internet Fax in an incompatible file format (PDF). Internet Faxing requires TIFF-F file format. Note: PDF file format is only used when using the Scan-to-Email feature.	Change the Fax Parameter No. 177 (XMT FILE TYPE) to " TIFF ".	149
729	Failed to authenticate (SMTP Authentication) when connecting with the SMTP Server.	Check the SMTP Authentication, User Name and Password. Contact the Network Administrator.	54 148
730	Cannot retrieve the Journal nor program the Internet Parameters and the Auto Dialer remotely via email from a PC.	Check that the Fax Parameter No. 158 (PC REMOTE UPDATE) is set to " Valid ".	148
731	The dialer buffer for manual dialing was full (50 stations) when the Relay Transmission Request was received.	Request the originator to resend the Relay Transmission Request after the reserved communication is finished.	--

Info. Code	Meaning	Possible Action	Page
800/814/ 816/825	Unit was requested to relay a document or Confidential Communication but has no capability.	Check with the other party.	--
815	Mailbox is full.	Install Optional Flash Memory Card.	--
826	Received Sub-Address is not registered in the Auto Dialer (One-Touch/ABBR. Dialing).	Check the Auto Dialer. Check the remote station.	--
870	Memory overflow occurred while storing documents into memory for transmission.	1. Transmit documents without storing into memory. Use Direct Transmission when using G3 Fax Communication. 2. Install Optional Memory Card.	24 180

NOTE

1. After identifying the problem and verifying the recommended action, if the Information Codes keep reoccurring or for help on Information Codes that appear on your machine but are not listed above, please contact your local Panasonic Authorized Dealer.
For mechanical failures, see the Troubleshooting section in the Operating Instructions (For Copy & Network Scan Functions).

USA Only

WARRANTY

PANASONIC DIGITAL DOCUMENT COMPANY MAKES NO WARRANTIES, GUARANTEES OR REPRESENTATIONS, EXPRESSED OR IMPLIED, TO CUSTOMER WITH RESPECT TO THIS PANASONIC MACHINE, INCLUDING BUT NOT LIMITED TO, ANY IMPLIED WARRANTY OF MERCHANTABILITY OR FITNESS FOR A PARTICULAR PURPOSE.

PANASONIC DIGITAL DOCUMENT COMPANY ASSUMES NO RISK AND SHALL NOT BE SUBJECT TO LIABILITY FOR ANY DAMAGE, INCLUDING, BUT NOT LIMITED TO DIRECT, INDIRECT, SPECIAL, INCIDENTAL OR CONSEQUENTIAL DAMAGES OR LOSS OF PROFITS SUSTAINED BY THE CUSTOMER IN CONNECTION WITH THE USE OR APPLICATION OF THIS PANASONIC MACHINE. SEE YOUR DEALER FOR DETAILS OF DEALER'S WARRANTY.

Copyright © 2004 Panasonic Communications Co., Ltd.

All rights reserved. Unauthorized copying and distribution is a violation of law. The contents of this Quick Guide is subject to change without notice.

Copyright © 2004 par Panasonic Communications Co., Ltd.

Tous droits réservés. Toute copie et distribution non autorisées sont interdites par la loi. Contenu sujet à changements sans préavis.

For Service, Call: _____

Panasonic Digital Document Company
Unit of Matsushita Electric Corporation of America
Two Panasonic Way
Secaucus, New Jersey 07094
<http://panasonic.co.jp/pcc/en/>

Panasonic Canada Inc.
5770 Ambler Drive, Mississauga,
Ontario L4W 2T3
<http://www.panasonic.ca>

T0804-0
DZSD002231-0
August 2004/Août 2004
Printed in Japan